

**Wolfpack**

www.wolfpack-d.com

# FA-50 Golden Eagle "ROKAF"

FA-50 골든이글 "대한민국공군"



**WP14820**

**1/48  
Scale**

1:48 Scale

The KAI T-50 Golden Eagle is a family of South Korean supersonic advanced jet trainers and light combat aircraft, developed by Korea Aerospace Industries (KAI) with Lockheed Martin. The T-50 is South Korea's first indigenous supersonic aircraft and one of the world's few supersonic trainers. Development began in the late 1990s, and its maiden flight occurred in 2002. The aircraft entered active service with the Republic of Korea Air Force (ROKAF) in 2005.

The FA-50 is manufactured as a light attack fighter developed from the T-50, a training aircraft, and is equipped with a wider vertical tail, a low visible formation lights and EL/M-2032 radar made by ELTA Systems in Israel. The main displays on the instrument panels has also been replaced with a new, wider display. And the FA-50 can also be equipped with AGM-65 Maverick missiles and AIM-9 Sidewinder AAMs. In addition, 500 lb bombs, JDAM and KGGB too. A total of 60 FA-50s are currently being built for the Republic of Korea Air Force, replacing the outdated F-5E/F Tiger II and KF-5E/F Jaegong-ho.

KAI T-50 Golden Eagle은 한국항공우주산업(KAI)이 록히드마틴과 함께 개발한 한국의 초음속 첨단 제트 훈련기 및 경전투기입니다. T-50은 최초의 국산 초음속 항공기이자 세계에서 몇 안 되는 초음속 훈련기 중 하나입니다. 1990년대 후반에 개발이 시작되어 2002년에 시제기의 첫 비행이 이루어져 첫 양산형인 T-50이 2005년 대한민국 공군에서 운용이 시작되었습니다.

FA-50은 훈련기인 T-50에서 발전된 경공격전투기로 제작되어 더 넓은 수직미익과 저명도편대등, 이스라엘 ELTA제 EL/M-2032 레이더를 장비합니다. 계기판의 디스플레이도 더 넓은 신형으로 교체되었고 무장으로 AGM-65 매버릭 미사일, AIM-9 사이드와인더 AAM도 장비할 수 있습니다. 그 외에 500파운드 폭탄과 JDAM, KGGB 역시 장비가 가능합니다. 현재 대한민국공군을 위해 총 60대의 FA-50이 제작되어 오래된 F-5E/F와 KF-5E/F를 대체하고 있습니다.

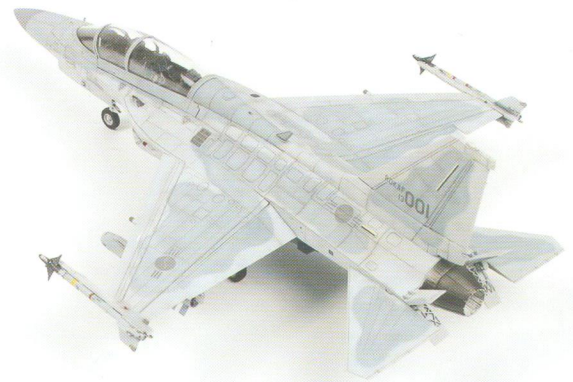

Work & Photo by Honghwan Jang

Contains one unassembled model kit only.  
No Paint and Cement in box.  
Kit suitable for Age to Adult.

조립되지 않은 키트가 들어있습니다.  
접착제와 도료는 들어있지 않습니다.  
15세 이상 판매용

Wolfpack-Design Co. Ltd.

F2, 352, Gwangdoek 4-ro, Sangroku, Ansan-si, Gyeongudo, 15489,  
Republic of Korea

울프팩디자인  
경기도 안산시 상록구 광덕4로 352, 2층 (우 : 15489)



# 1 Ejection seats Assembly (사출좌석 조립)

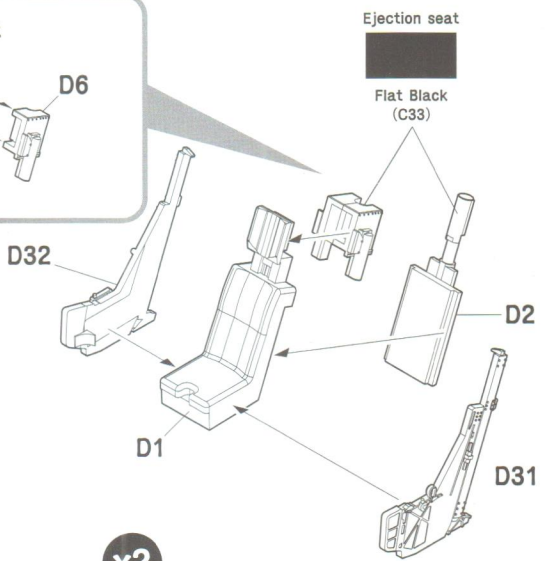
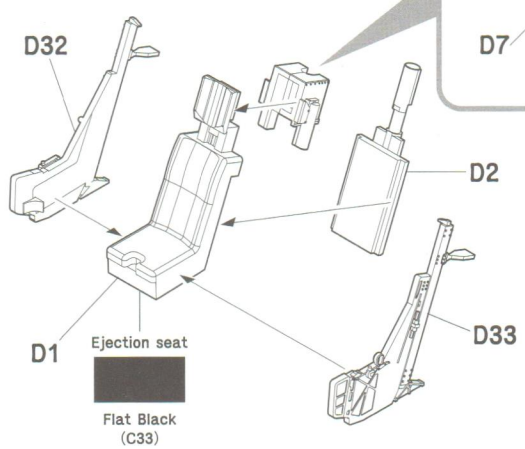
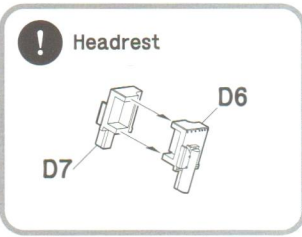

\*Reference photos

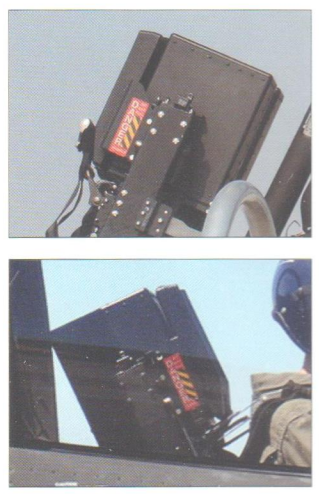

● : Decal number (데칼번호)

\*Color number : GSI Creos Mr. Color.

x2

## 5 Front & Rear

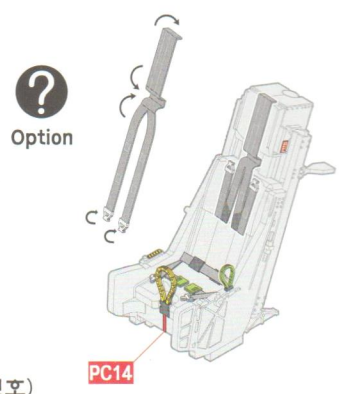
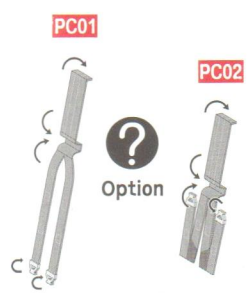
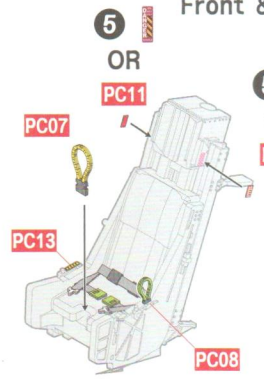
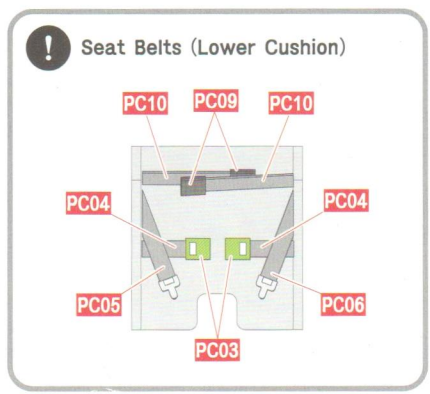

■ : Color PE Number (컬러에칭 번호)

# 2 Cockpit Bath-tub (조종석 바스터브)

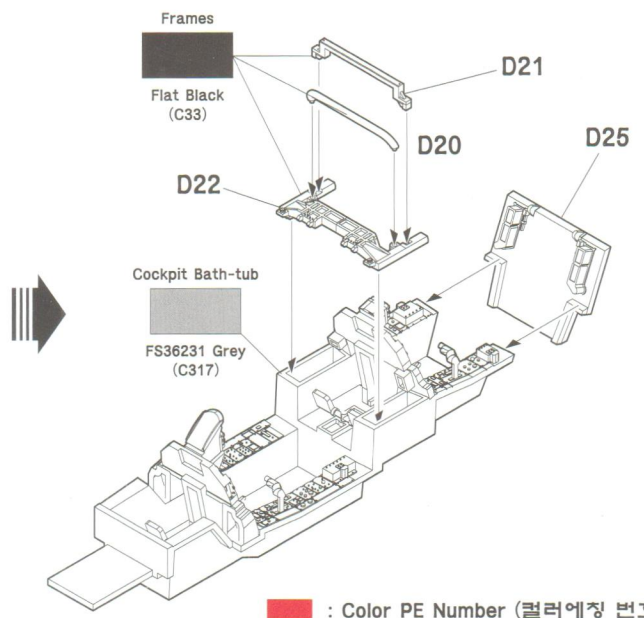
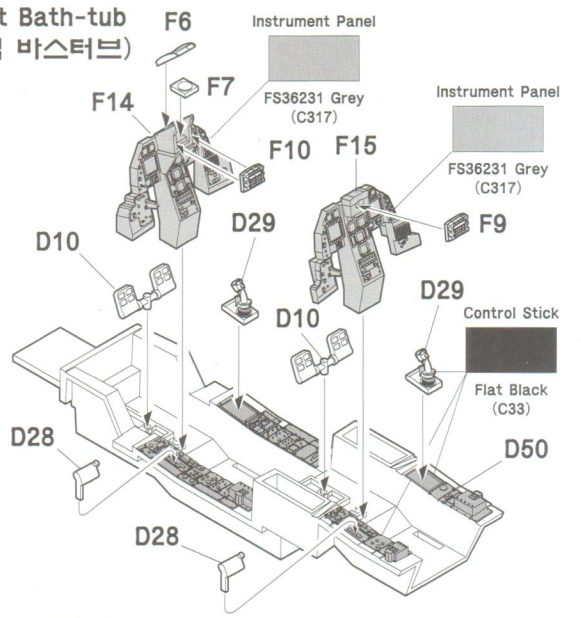

**!** Remove the molds from the surface before attaching the colored PE parts.

■ : Color PE Number (컬러에칭 번호)



## ! Front Instrument Panels

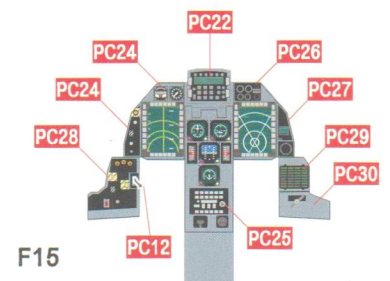
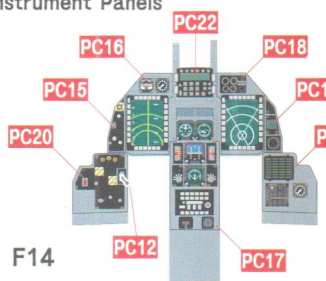



### 3 Cockpit Bath-tub & Front Wheel bay (조종석 바스터브와 전방 휠베이)

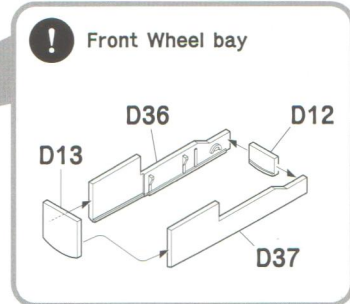
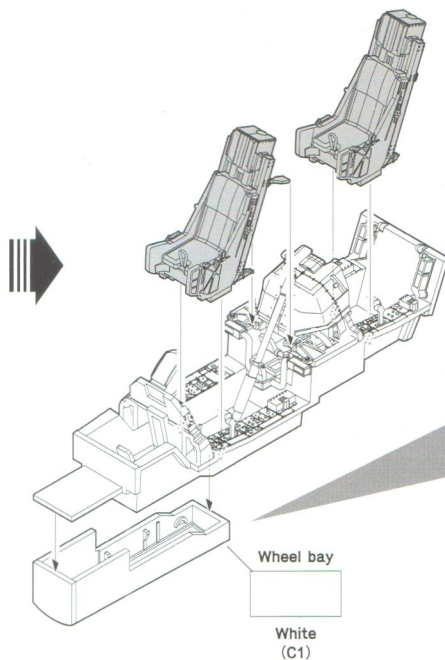
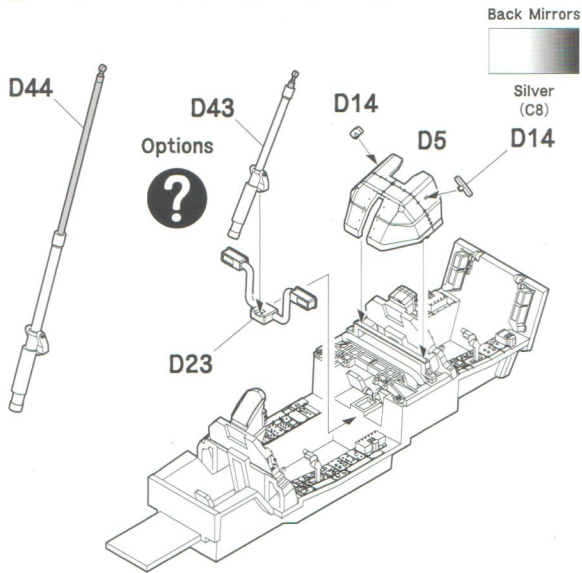

### 4 Intake & Wheel bay (인테이크 & 휠베이)

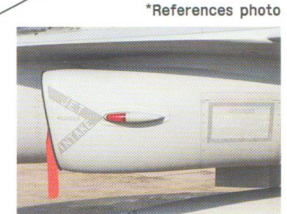
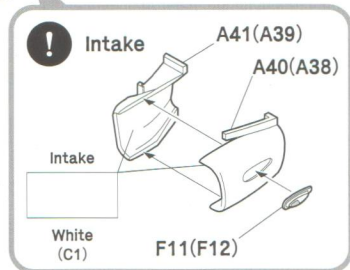
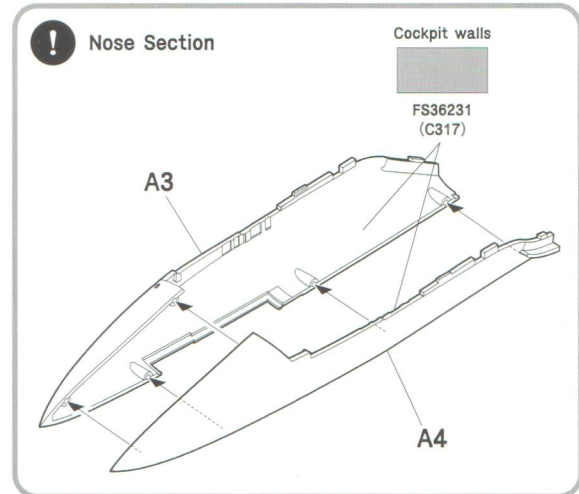
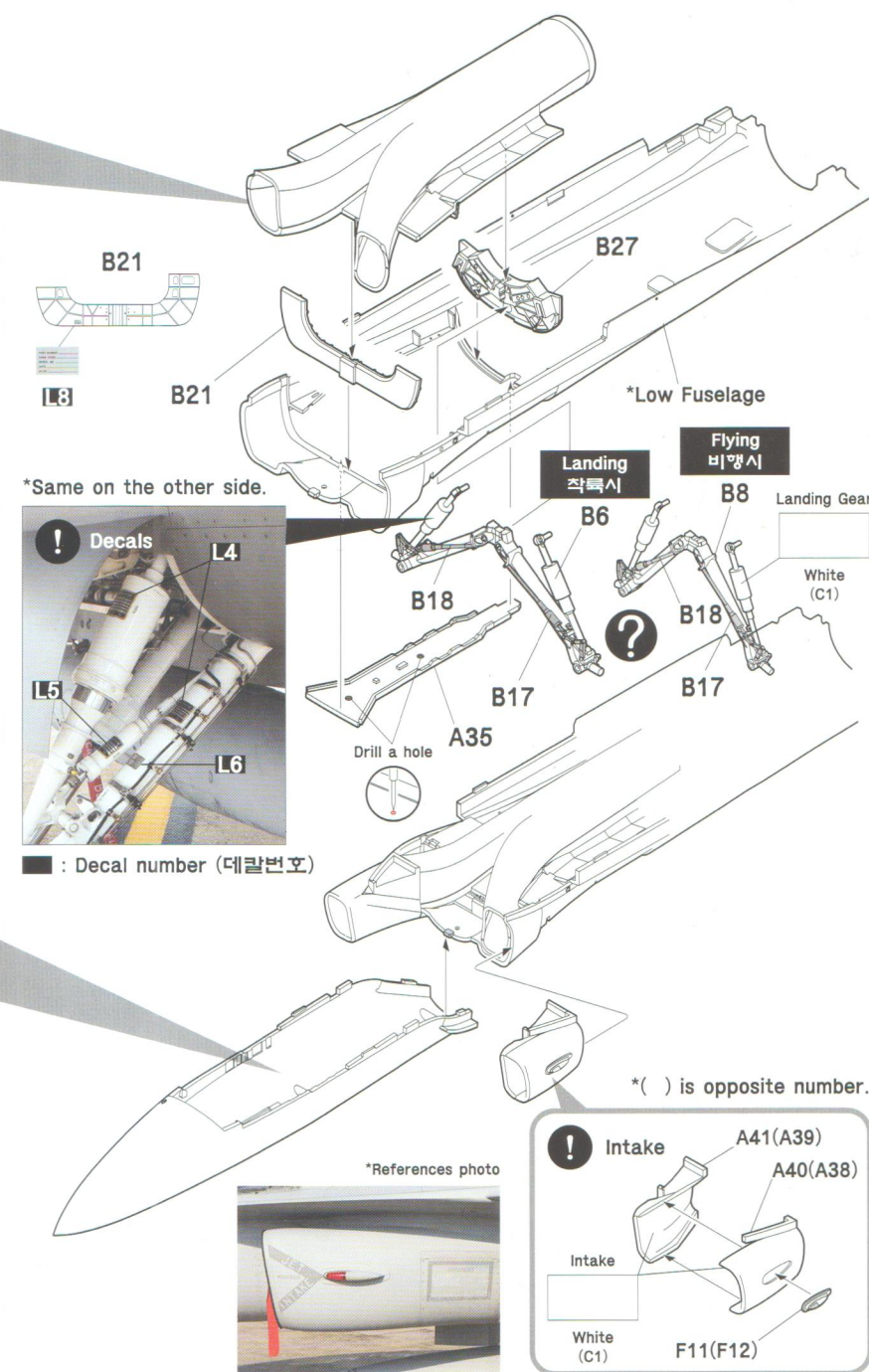
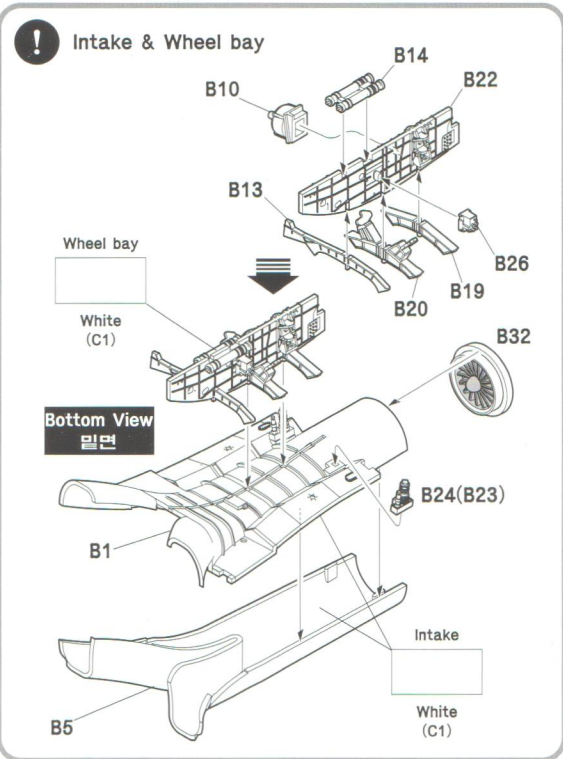



# 5 Fuselage & Main Wings (동체와 주익 조립)

Bottom View  
밑면

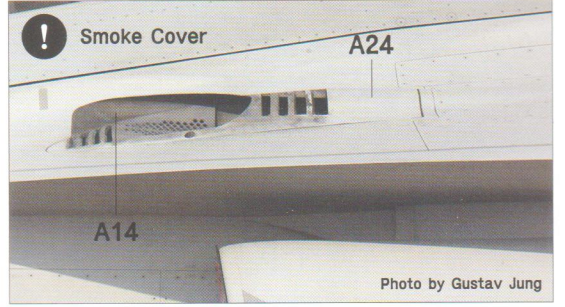
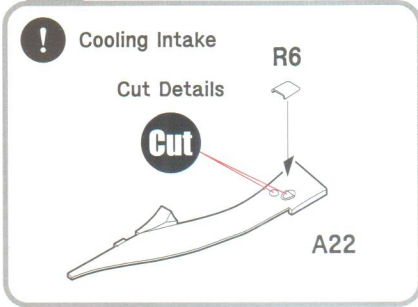
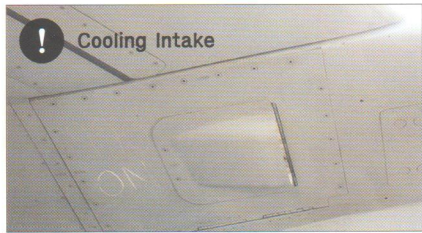
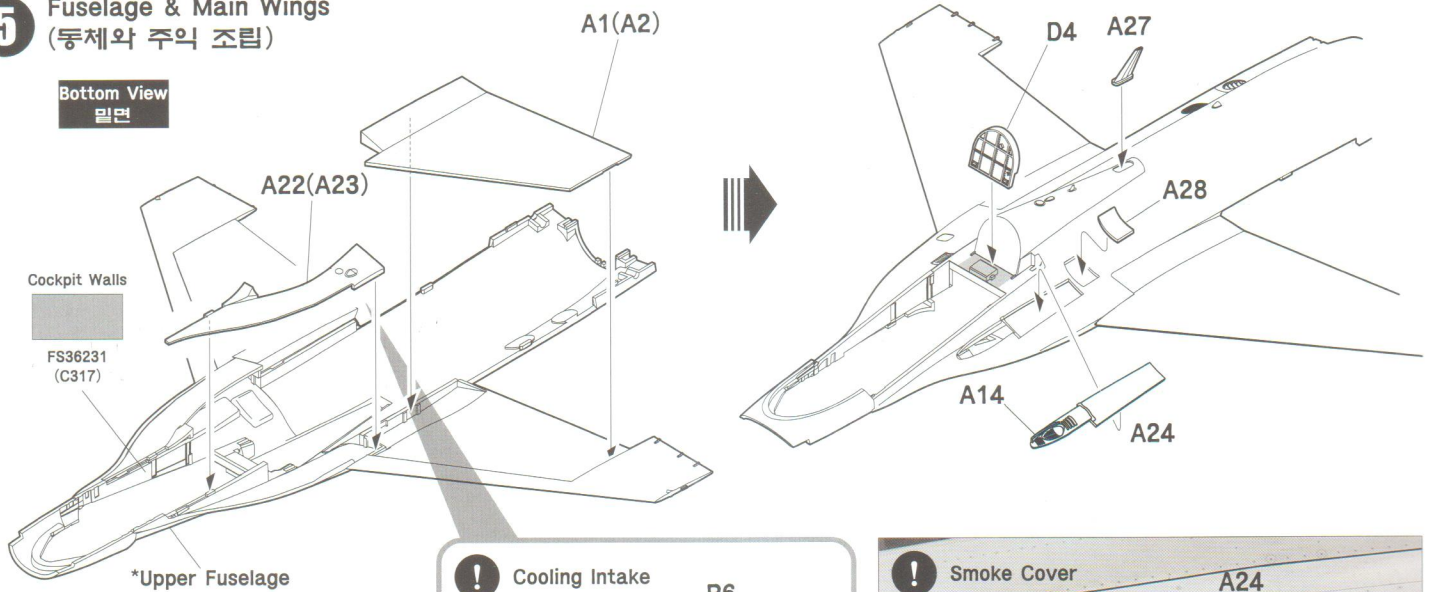

# 6 Fuselage Assembly (동체상하조립)

1 2 5 Options

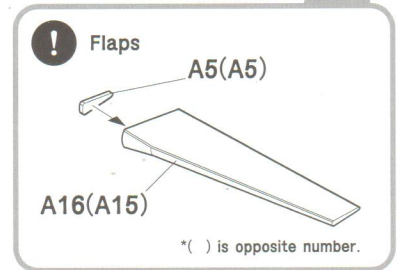
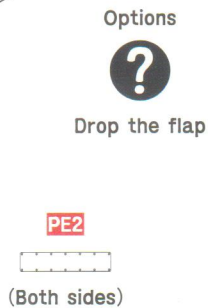
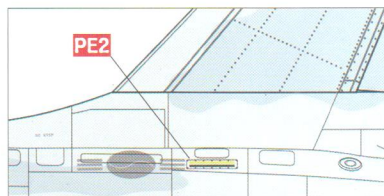
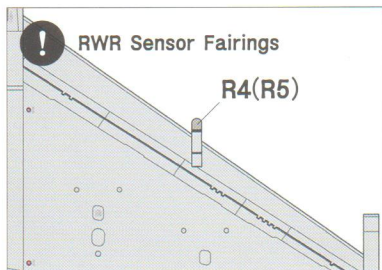
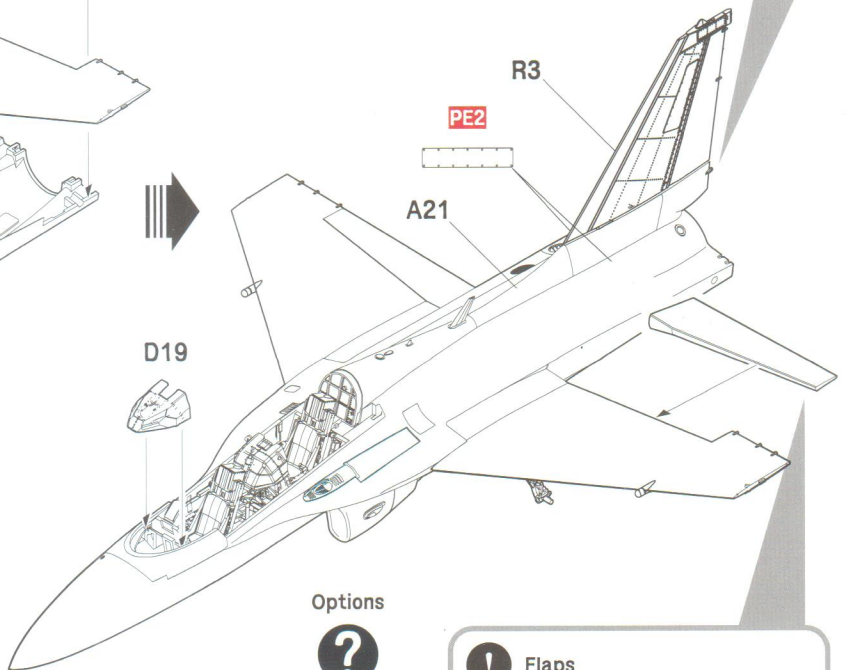
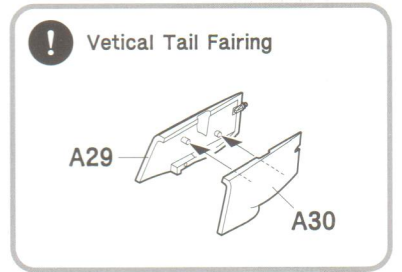
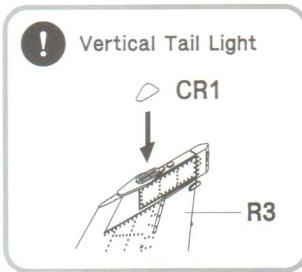
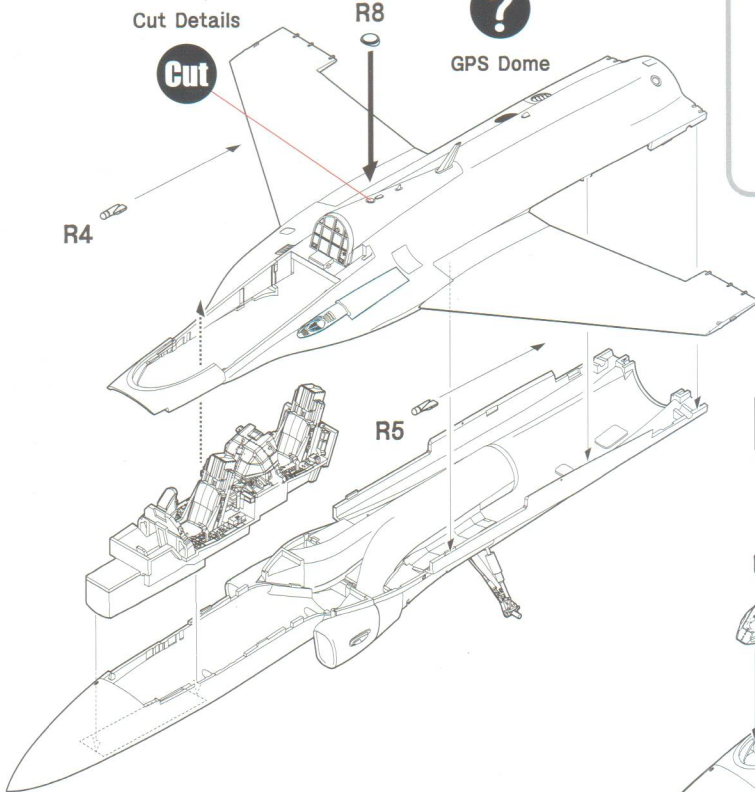

\*( ) is opposite number.



## 7 Air-Brake & Exhaust Assembly (에어브레이크와 배기구 조립)

\*( ) is opposite number.

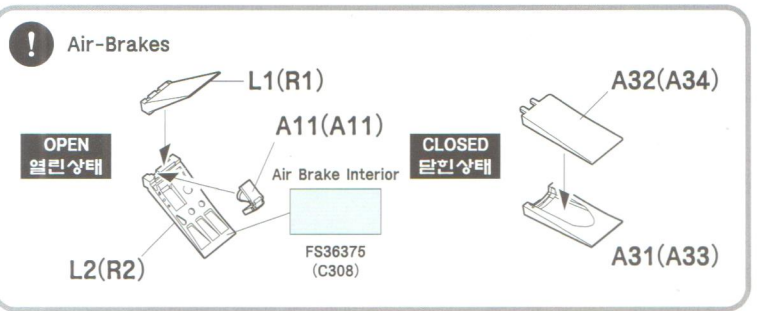
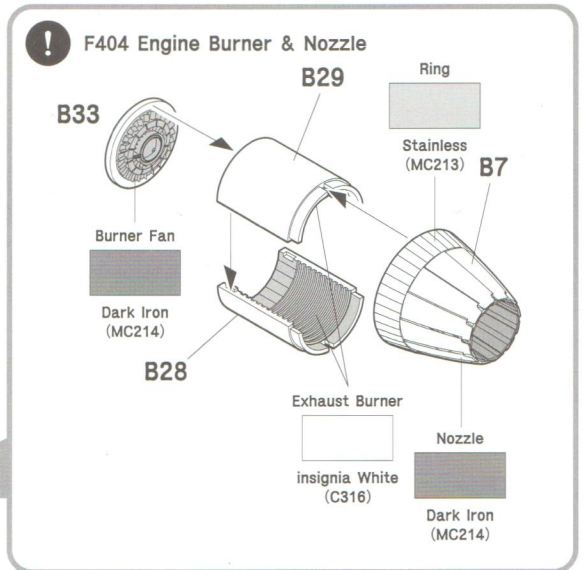
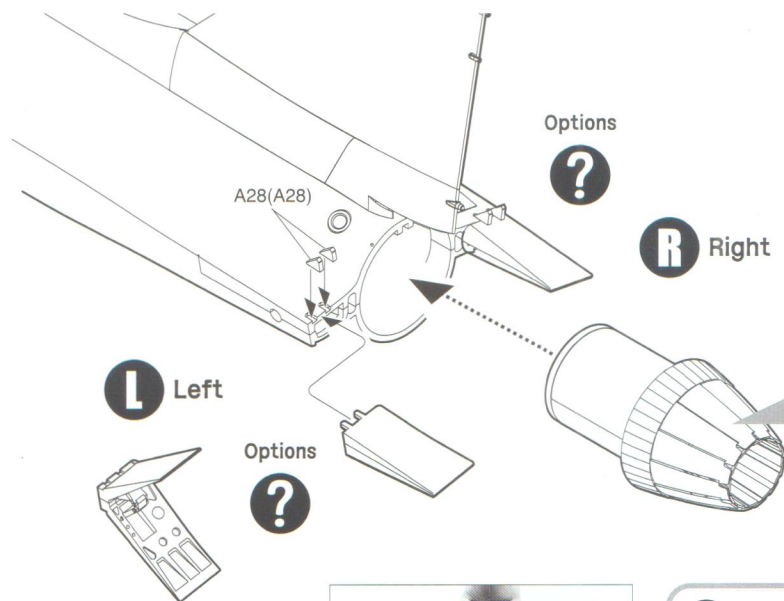

## 8 Horizontal Tail Wings & Wing Tip Launchers (수평미익과 날개끝 미사일 런처)

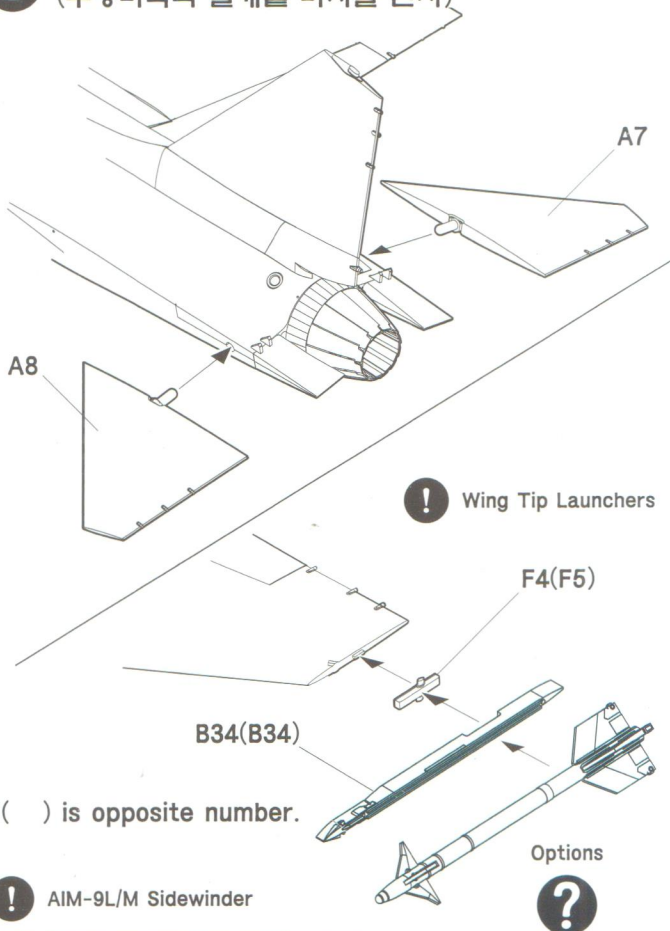

\*( ) is opposite number.

! AIM-9L/M Sidewinder

\*AIM-9 Sidewinder is not in the kit. Please get it from another kit.

## 9 Front Landing Gear Door (전방 랜딩기어 도어)

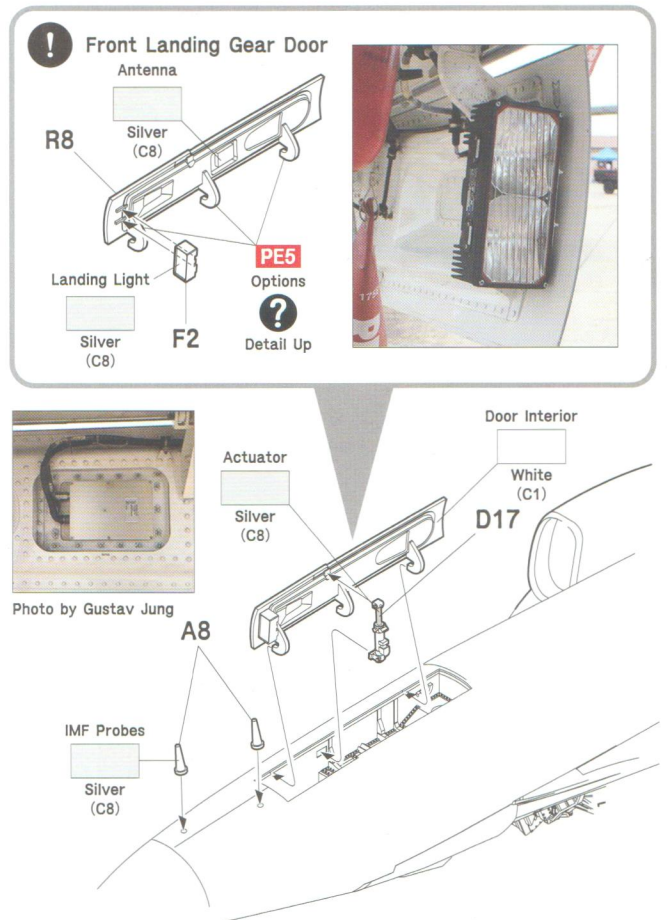



# 10 Nose Landing gear Asseby (노즈 랜딩기어 조립)

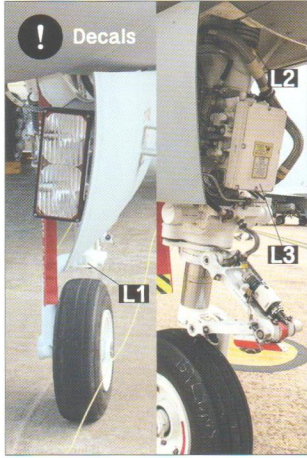

! Decals  
: Decal number (데칼번호)

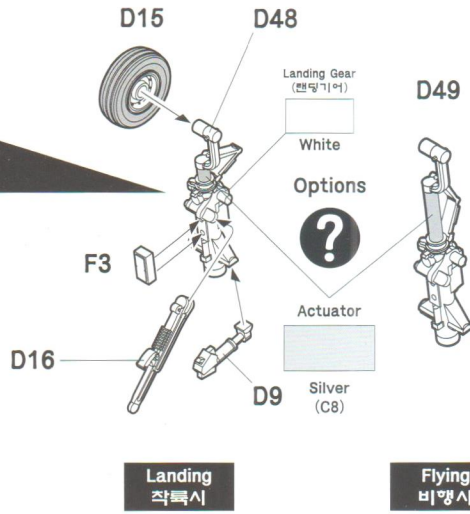

Landing 작륙시

Flying 비행시

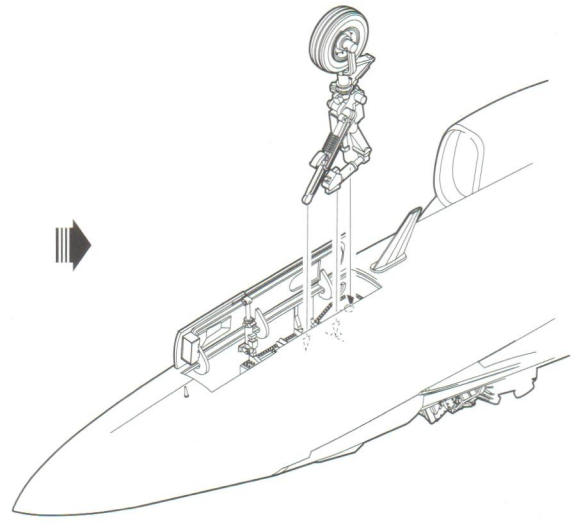

# 11 Main Wheels & Arresting Hook (메인 휠 조립과 어레스팅 후크)

Bottom View 밑면

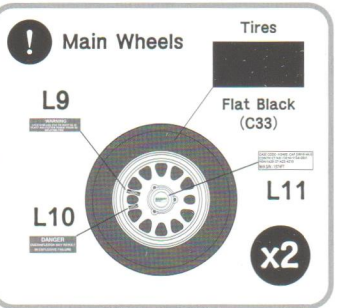
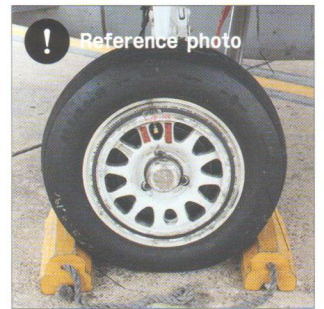
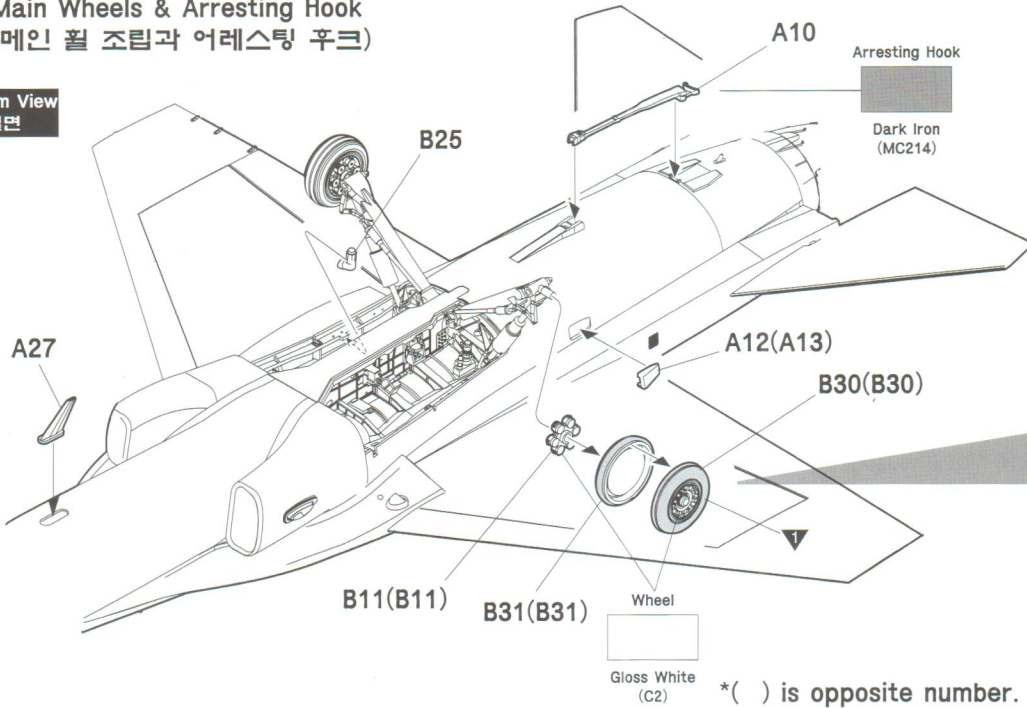

# 12 Main Landing Gear Covers (메인 랜딩기어 커버 조립)

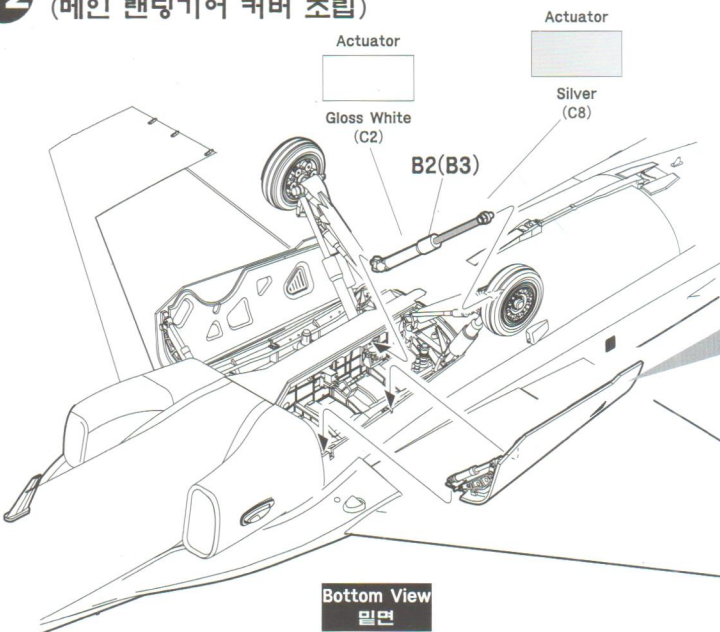

Bottom View 밑면

\*( ) is opposite number.

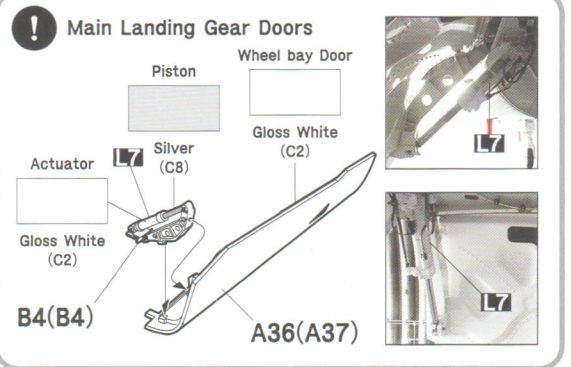



# 13 Canopy Assembly (캐노피 조립)

## ! Canopy & Canopy Frames

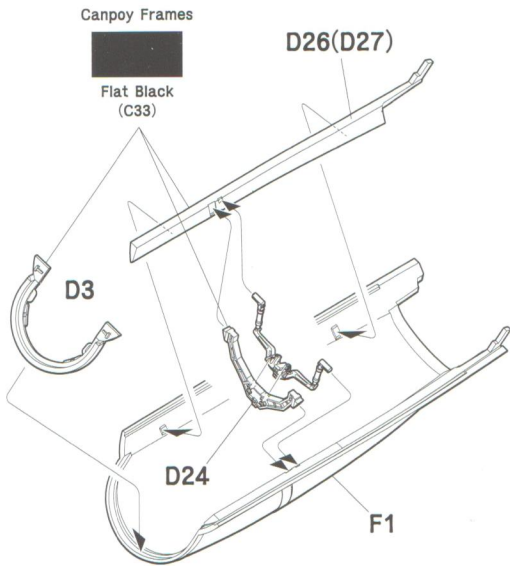
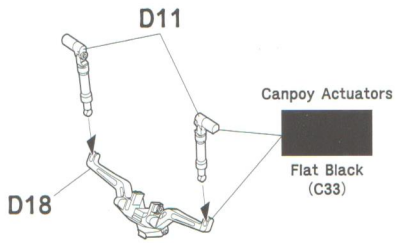

\*( ) is opposite number.

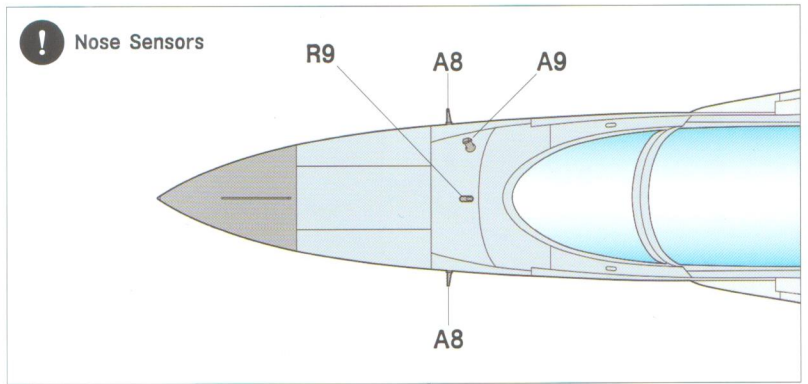

## Options



**CLOSED**  
닫힌상태

Pitot Tube  
Dark Iron (MC214)

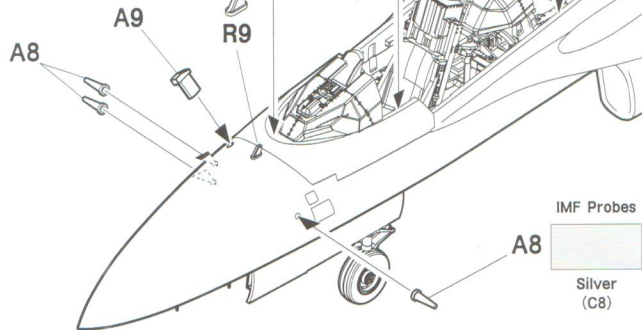

# 14 Canopy Open & Boarding Ladders (캐노피 오픈 및 탑승 사다리 조립)

## Options



**OPEN**  
열린상태

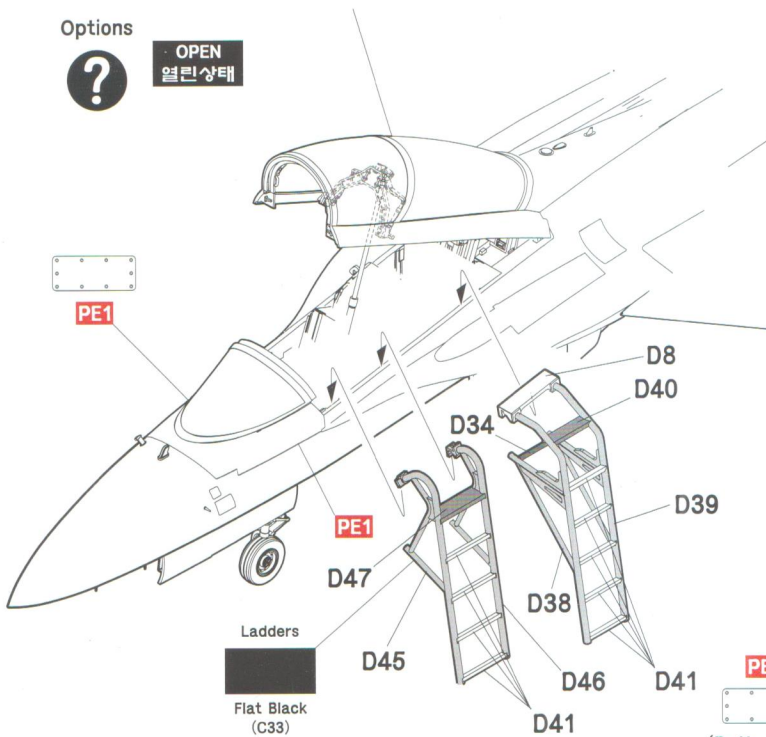

## ! Canopy & Canopy Frames

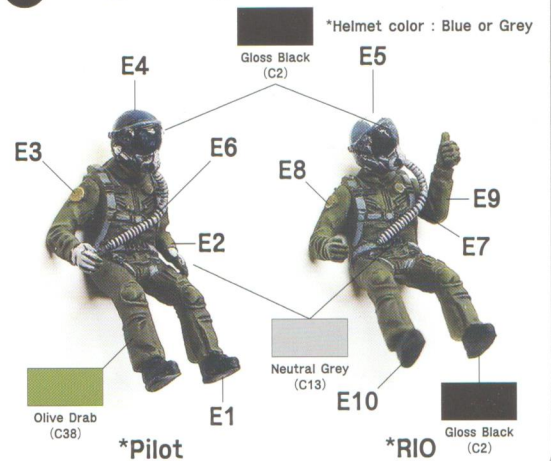

## ! Formation Lights

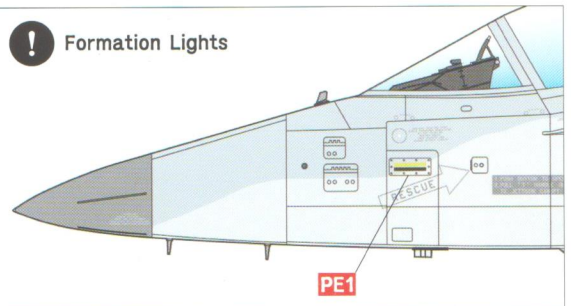

(Both sides)



# 15 External Fuel Tank (외부 연료탱크)

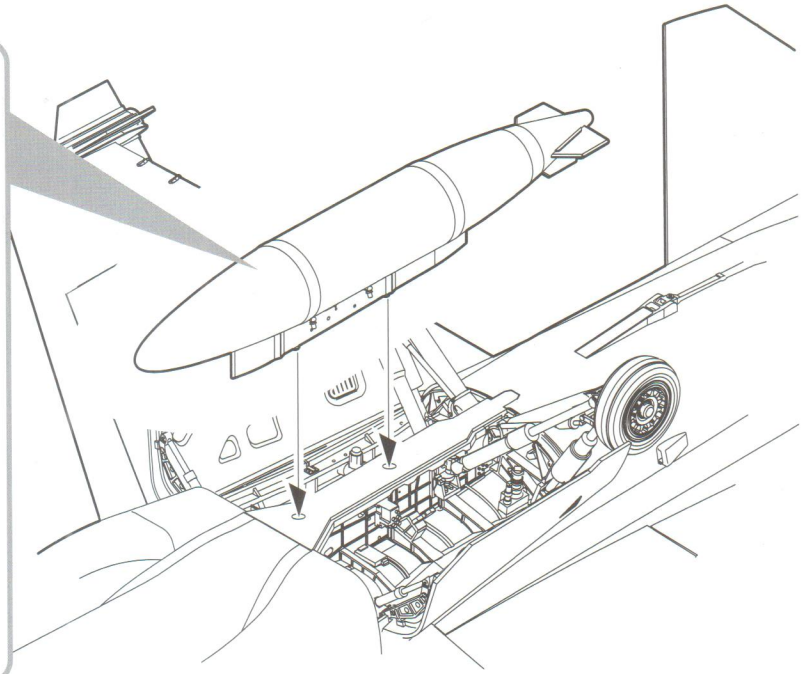
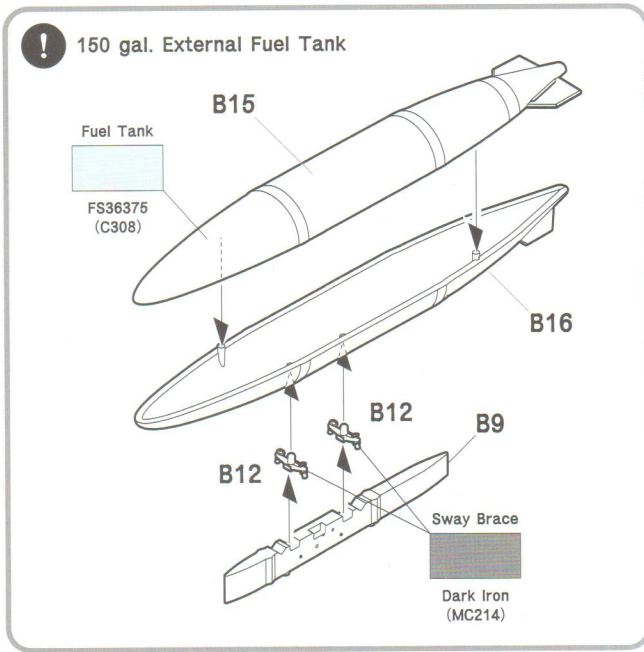

# 16 Wing Pylons (주익 파일런들)

## ■ Wing Pylon (Inner) x2

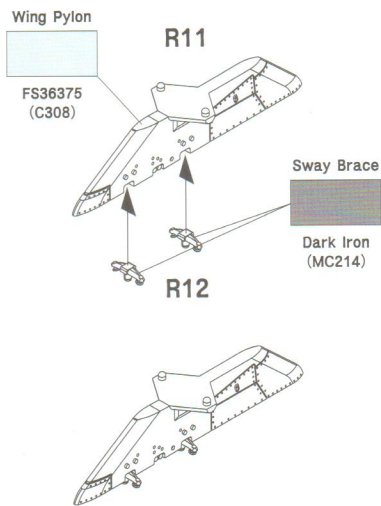

## ■ Wing Pylon (Outer) x2

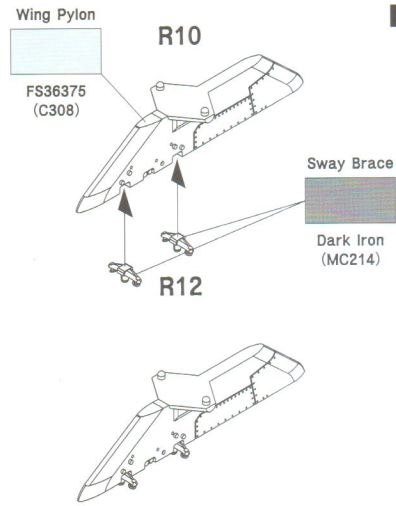

## ■ Wing Pylon (Inner)

## ■ Wing Pylon (Outer)

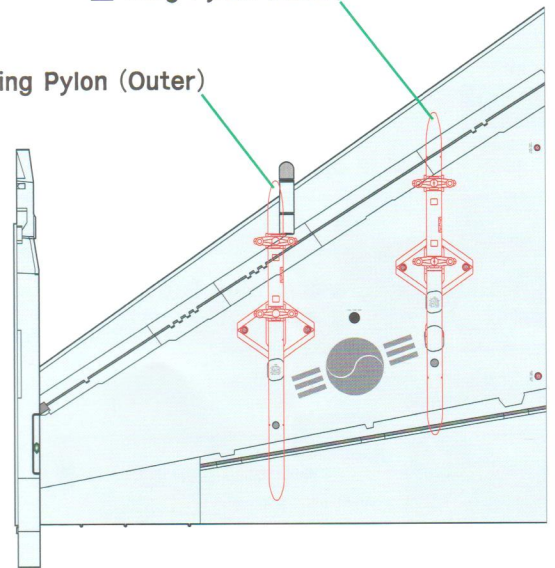

# ! Canopy & Wheel Masking Seal (캐노피와 휠 마스크)

**M**

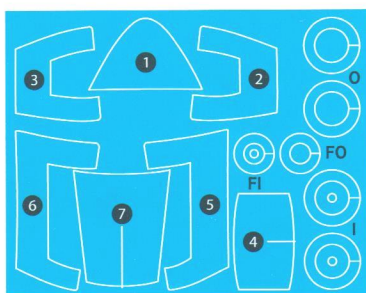

\*M (Masking Seal)

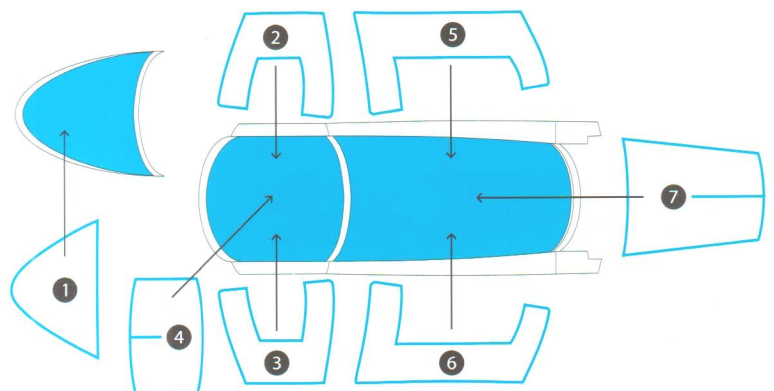

\*Wheel Mask - F0 & F1 : Front Wheel / O & I : Main Wheels



**Basic Stencils (Top & Bottom)**

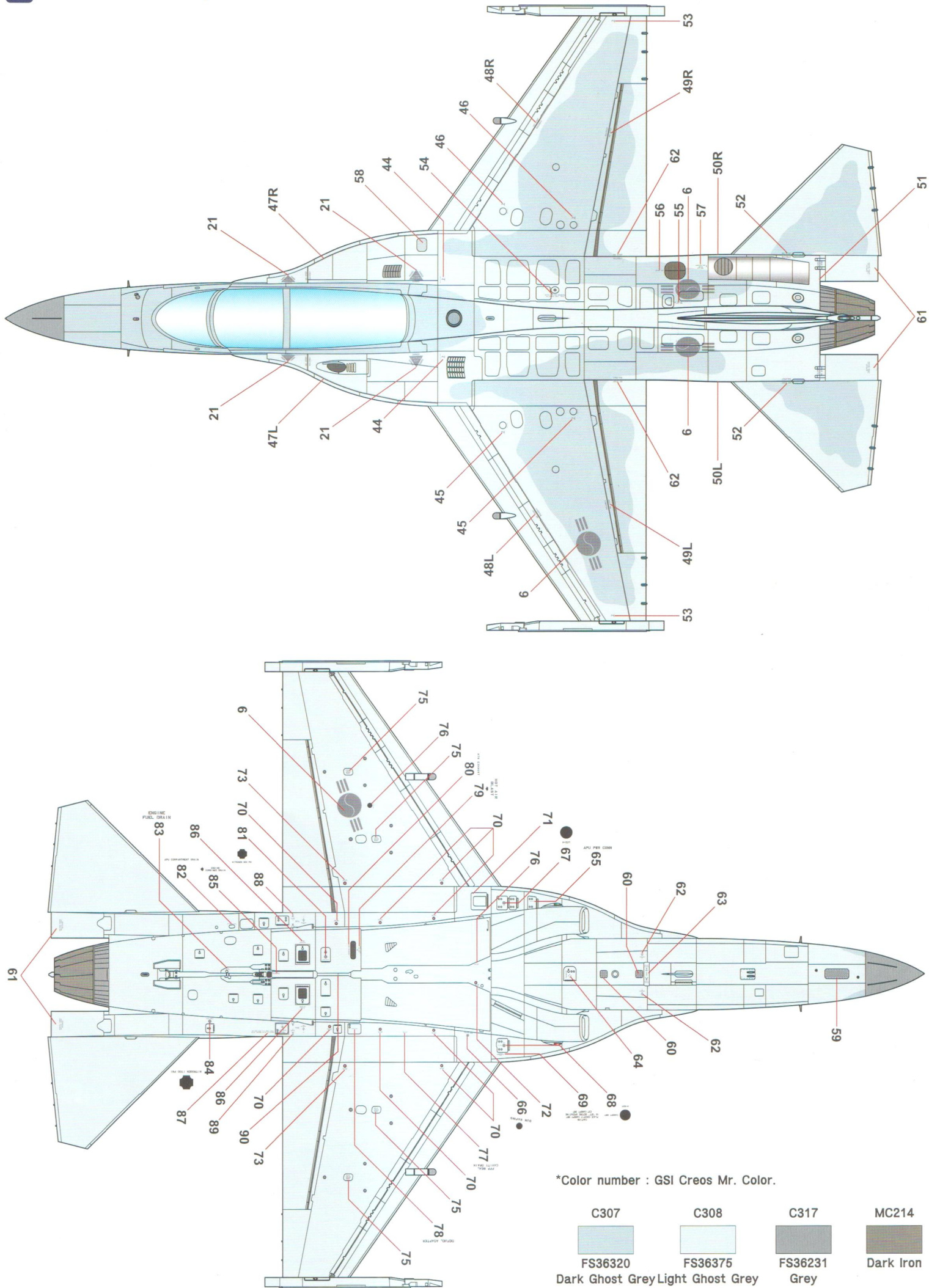

\*Color number : GSI Creos Mr. Color.

C307	C308	C317	MC214
			
FS36320	FS36375	FS36231	Dark Iron
Dark Ghost Grey	Light Ghost Grey	Grey	



**!** Basic Stencils (Side)

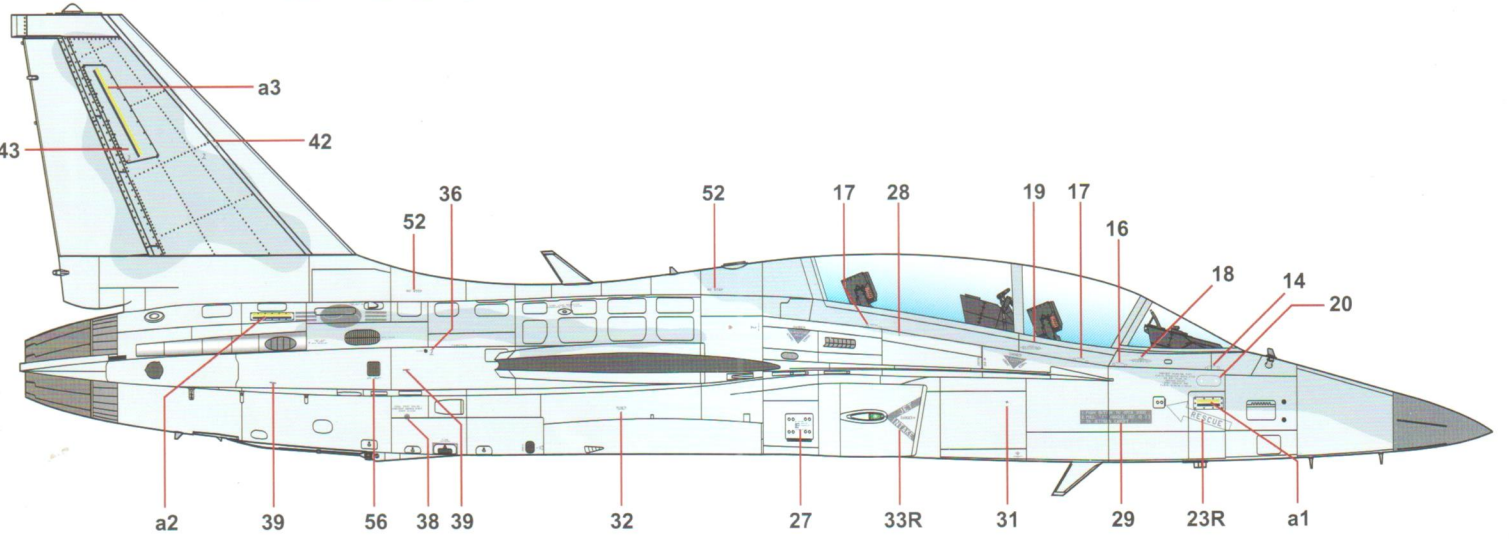
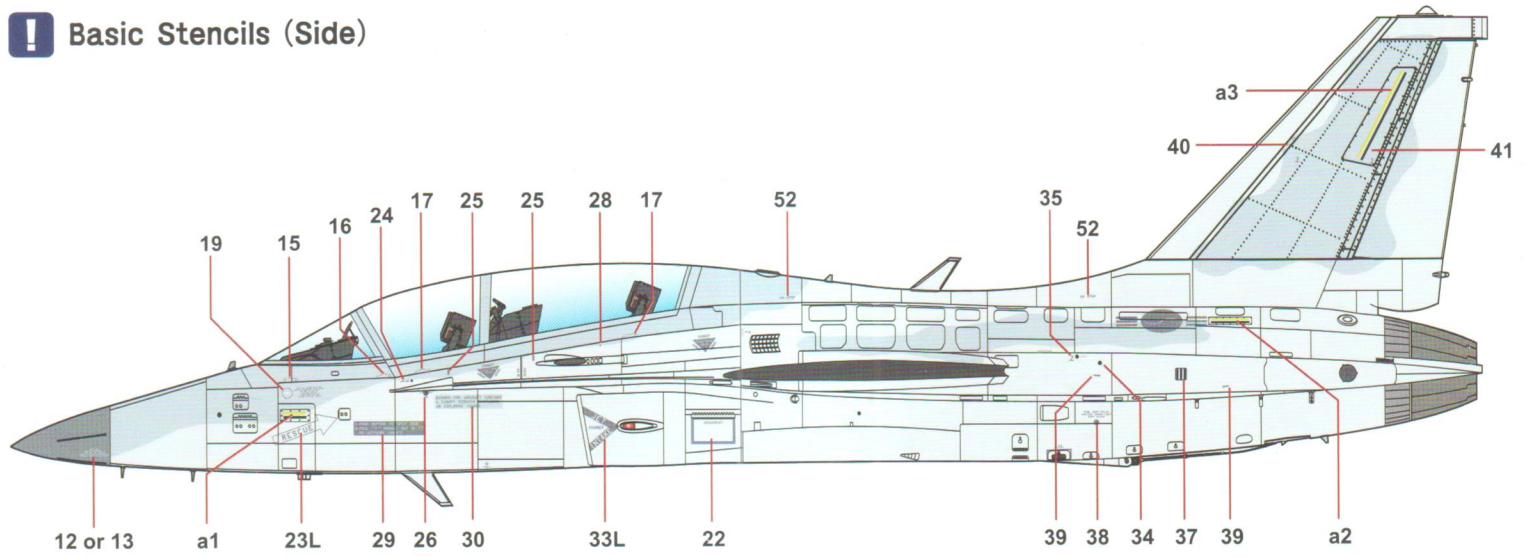

**1** ROKAF FA-50 Golden Eagle, S/N 15-0024, 281st Test & Evaluation Squadron, 52nd Test & Evaluation Group, Observation flight for KF-21 Prototype Test Flight in Sacheon AFB, July 19, 2022

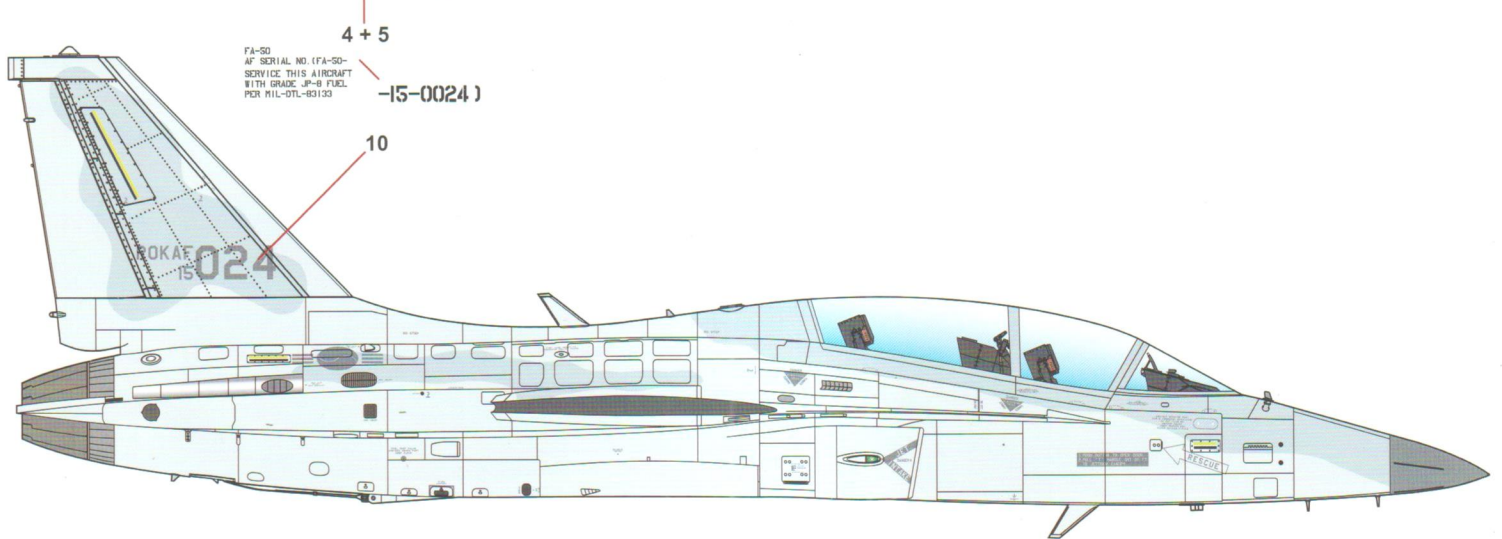
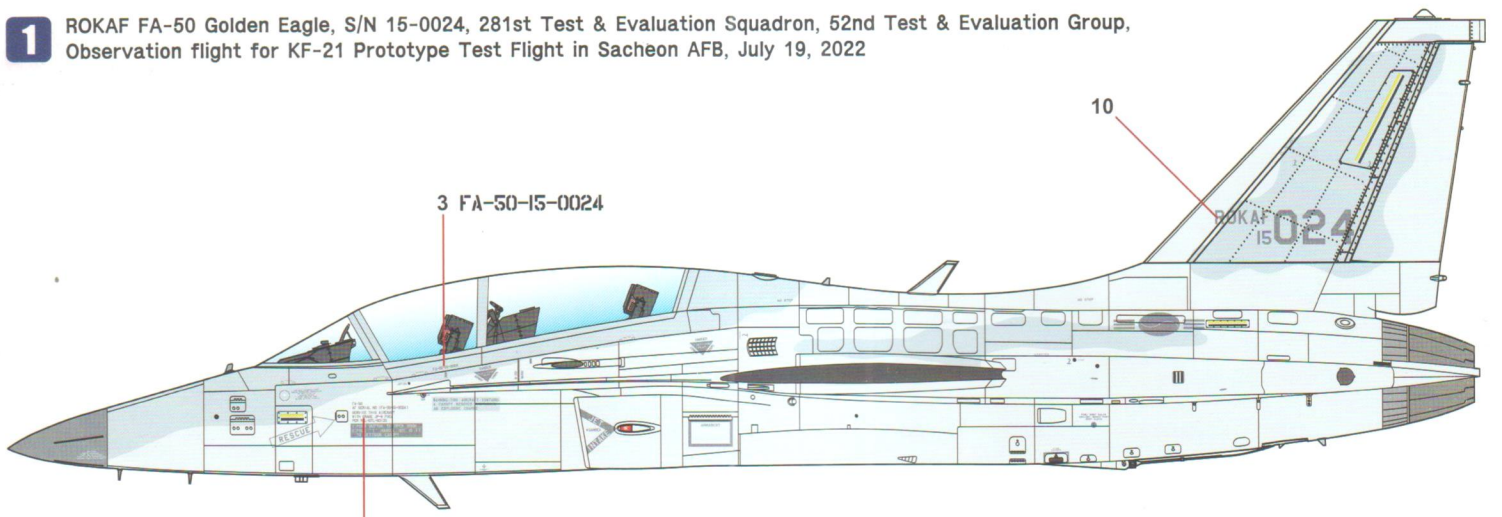

FA-50  
AF SERIAL NO. (FA-50-  
SERVICE THIS AIRCRAFT  
WITH GRADE JP-8 FUEL  
FOR MIL-DTL-89133)

-15-0024 )



**2** ROKAF FA-50 Golden Eagle, S/N 16-0041, 202nd Fighting Squadron, 16th FW, Yecheon AFB  
 Observation flight for KF-21 Prototype Test Flight in Sacheon AFB, July 19, 2022

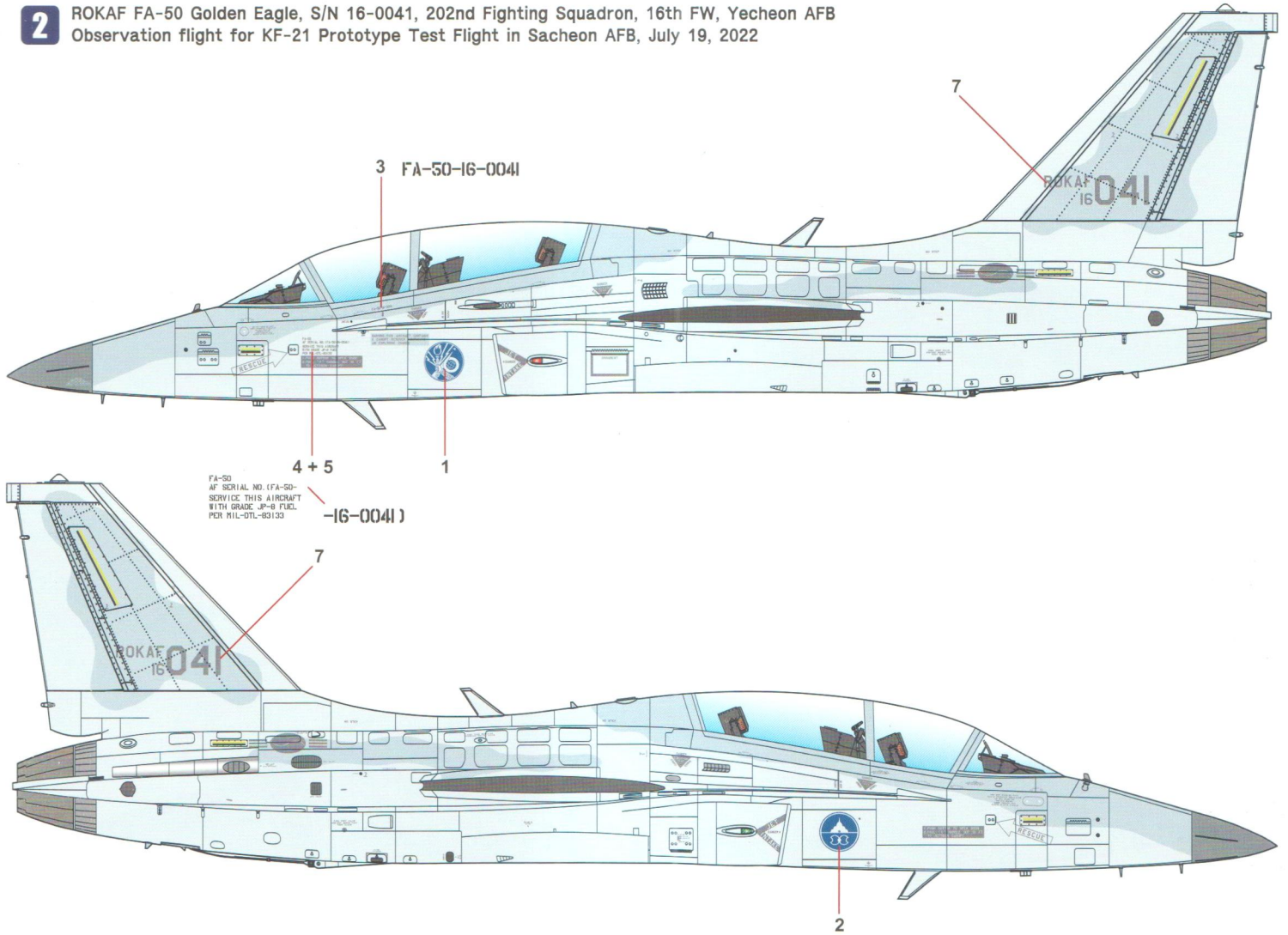

**3** ROKAF FA-50 Golden Eagle, S/N 13-0001, 103rd FS, 8th FW, Wonju AFB,  
 Participated in the demonstration flight of ADEX 2021, Oct. 2021

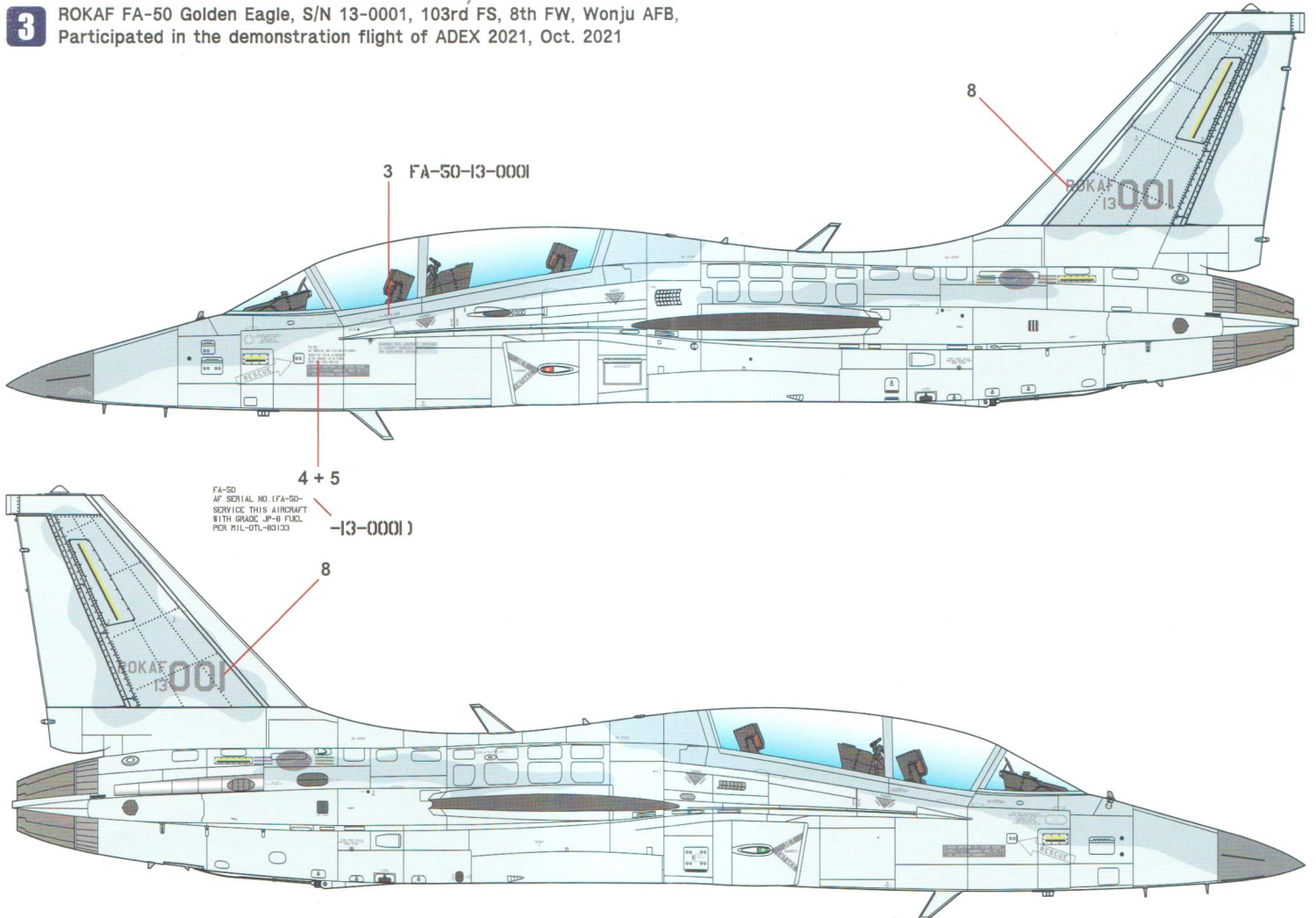



**4** ROKAF FA-50 Golden Eagle, S/N 13-0002, 103rd FS, 8th FW, Wonju AFB,  
Participated in the demonstration flight of ADEX 2021, Oct. 2021

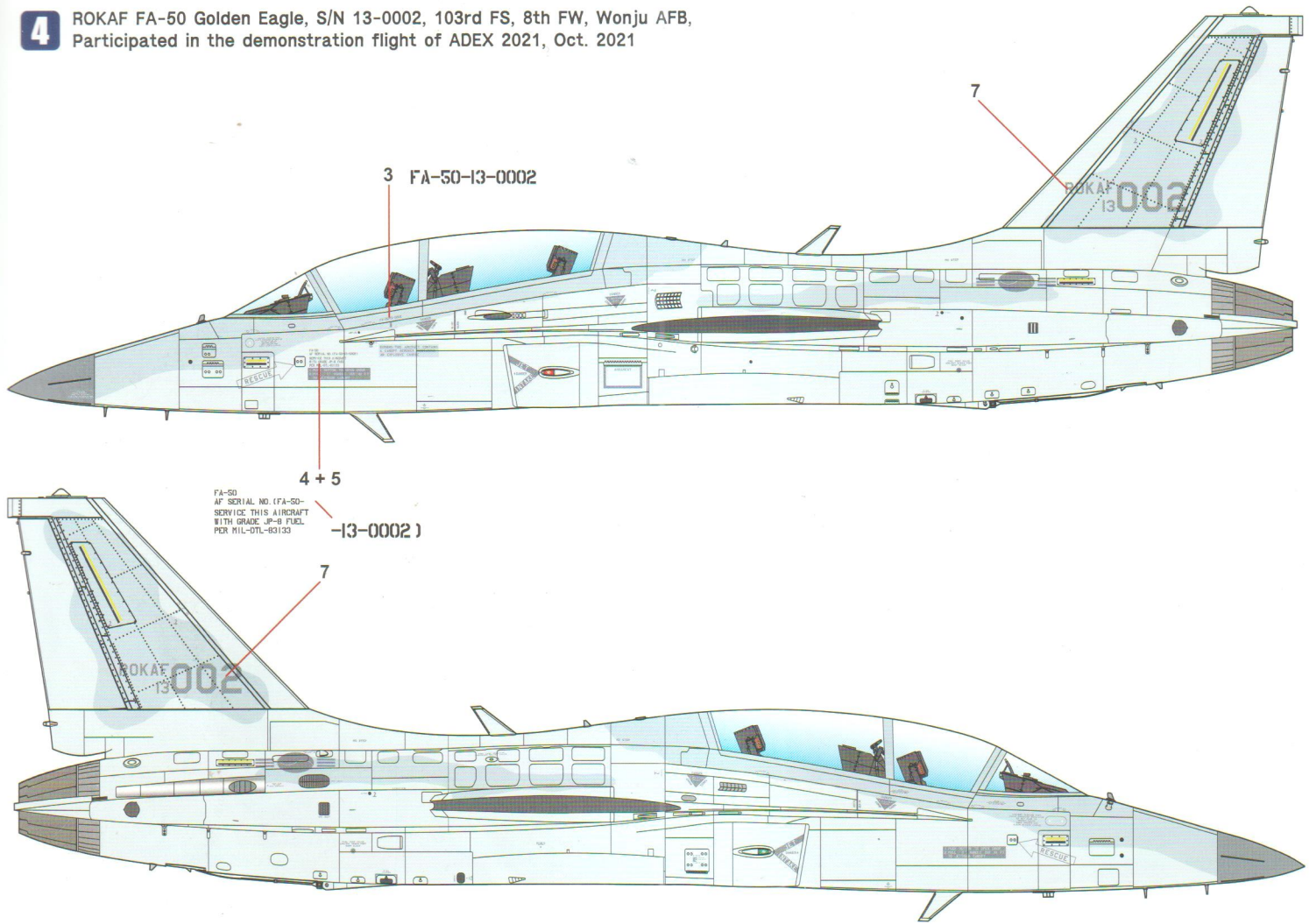

**5** ROKAF FA-50 Golden Eagle, S/N 16-0050, 203rd FS, 8th FW, Wonju AFB,  
Participated in Exercise Buddy Squadron 22 with the USAF at Osan AFB, July 2022

